

LED SMART FLOOD LIGHTS

SMTFLOOD

DIMMABLE 5000K + RGB



**NO HUB
REQUIRED**



Technical Features:

- Input voltage range: 220-240V 50/60Hz
- Inbuilt constant current LED driver included
- Housing: powder coated aluminium
- Heatsink: aluminium
- Diffuser: glass
- LED chips: SMD2835
- CRI: ≥ 80
- Power factor: ≥ 0.9
- Ambient temperature: -20 to 40°C
- Flex & Plug: 1.2m
- **App: control all functions via Tuya app on smart devices**
- **Manual: on/off control via normal wall switch**
- **Dimmable only via app or voice control through Amazon Alexa, Google Home and other compatible voice activated control devices (Not compatible with wall switch dimmer)**
- Setup requires WiFi with Internet connection
- Suitable for 2-way switching
- Not suitable for use with sensor



Additional SMART Features:

- Tuneable RGB colour spectrum (up to 14 million colours)
- Default colour temperature: 5000K
- Works with any 2.4GHz enabled WiFi network (note: will not currently pair with 5.0GHz bandwidth.) or Bluetooth LE 4.2
- Create schedules plans, Biorhythm and timing to automate your home
- Ability to set power-on behaviour
- Control from anywhere via app or voice control using Alexa Hubs, Google Home and other compatible devices
- Compatible with all Tuya Powered apps

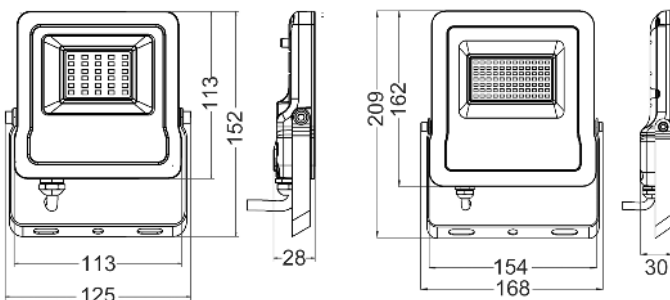

SMTFLOOD1

SMTFLOOD2

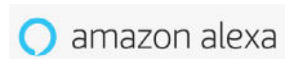

Part No.	Description	Kelvin	Lumens	Watt	Product Dimensions	Weight	Box Dimensions	Carton QTY
SMTFLOOD1	FLOOD LED SMART Black Dimm 5K+RGB 10W	5000K	800LM	10W	152x125x28mm	0.6kg	19.5x4.5x16.5cm	1/20
SMTFLOOD2	FLOOD LED SMART Black Dimm 5K+RGB 30W	5000K	2400LM	30W	209x168x30mm	0.9kg	17.5x63x22cm	1/20